

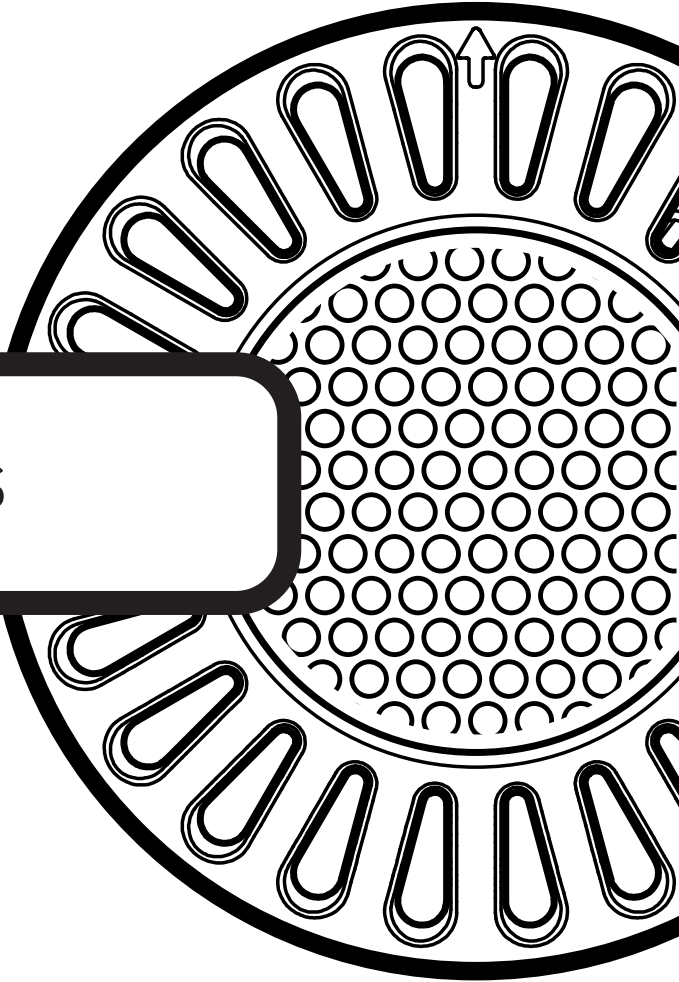

atom

VINYL POOLS



EMV

INSTALLATION & OWNER'S MANUAL

CONTENTS

READ THIS FIRST	3
TOOLS REQUIRED	4
PRODUCT SUPPORT AND INFORMATION	4
INCLUDED PARTS	5
FINISHED INSTALLATION	6
INSTALLATION PROCEDURE	7
LIGHT ASSEMBLY	13
LIGHT REMOVAL	14
CABLE ADJUSTMENT & REMOVAL	16
KEY DIMENSIONS	18

NOTICE



HORIZONTAL MOUNT ONLY
NOT INTENDED FOR OPERATION OUT OF WATER

READ THIS FIRST

Congratulations on your purchase of the **ATOM** underwater lighting system. All **ATOM** lights are manufactured by Spa Electrics in Australia from only the highest quality materials. For more information about Spa Electrics & our products, please visit www.spaelectrics.com.au

BEFORE YOU START:

- **ATOM** cables can be shortened to suit individual installation requirements. Spa Electrics recommends all cabling is protected by conduit and that a junction box (or similar) is incorporated into pool cabling design to avoid siphoning.
- Ensure that the lighting system is installed by a qualified person (e.g. registered pool builder and/or licensed electrician), in accordance with the most current edition and/or amendment of current AS/NZS 3000 Wiring Rules.
- For safe and proper installation, ensure that only those parts supplied with the system are used.
- Maximum installation depth for the **ATOM** light is 400mm (16") below water line (to top of light).
- All lights should be mounted in a location that is easily accessible without the need for entering or lowering the pool water.
- 700mm (28") cable has been supplied pre-assembled within niche assembly, and must remain stored within the Niche to ensure the light can be accessed above the waterline. (Maximum cable within niche - 1000mm (40") (up to 1.0mm²). See Page 16 for more information).

CLEANING

- Only use warm water and a soft brush or cloth to clean **ATOM** lights. **DO NOT** use detergents or spirits as this can damage the light and void your warranty.

USE OF PRODUCT

- **DO NOT** operate light unless completely submerged in water.
- Operating the light for at least 30 minutes every week is advised (all year round).
- **ATOM** lights are suited for both domestic and commercial installations and can be operated continuously (24/7) if required.
- Temperature range for installation, operation and servicing: +5°C ~ +40°C (+41°F ~ +104°F)

IMPORTANT NOTE



It is recommended that the ATOM lighting range is operated using a Spa Electrics LV25-12 or LV50-12 transformer.

- DO NOT use electronic or switch-mode power supplies with ATOM lights. These power supplies will damage the light and void your product warranty.
- Pool chemicals & PH levels: Due to corrosive nature of unbalanced pool chemicals, Spa Electronics strongly recommend that your pool water is balanced prior to installing your pool lights or any plastic or stainless steel components, and tested weekly to maintain these levels. PH levels should be maintained between 7.2 - 7.6 at all times to ensure the longevity of these components.
 - » Failure to do so can result in chemical damage to the light housing and pool fittings, including stainless steel components.
 - » Please note: Lights or components found to have excessive chemical damage will not be covered under our manufacturer's warranty policy.
- This light containers no user-serviceable parts; opening the light will void the product warranty.

TOOLS REQUIRED

- ✓ Hole Saw - $\emptyset 65\text{mm}$ ~ $\emptyset 70\text{mm}$ (2 5/8" ~ 2 3/4" saw)
- ✓ No. 2 Phillips screwdriver
- ✓ Box cutter / Knife
- ✓ Flat-blade screw driver (for light-head removal)

IMPORTANT NOTES



- The use of power tools for product ssembly is **NOT** recommended as these devices can cause faults and damage to light components.
- The enclosed images are for illustrative purposes only. Appearances of parts and assemblies may vary from the enclosed illustrations.
- Please contact your reseller if you have any questions regarding the correct installation of this product.

PRODUCT SUPPORT & INFORMATION

Phone: +61 03 9793 2299 (business hours)

Email: info@spaelectrics.com.au (SALES enquiries)

Email: tech@spaelectrics.com.au (TECHNICAL support enquiries)

Web: www.spaelectrics.com.au

INCLUDED PARTS

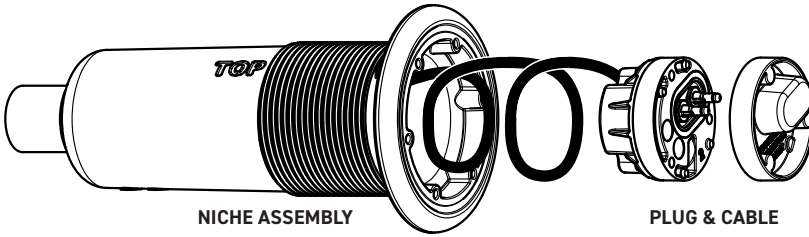

NICHE ASSEMBLY

PLUG & CABLE

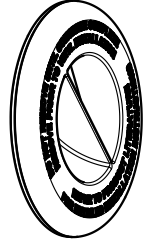

NICHE CAP

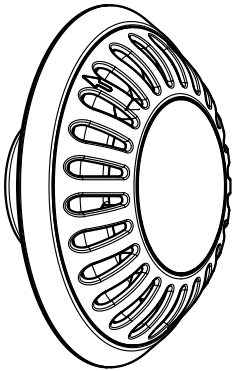

LIGHT

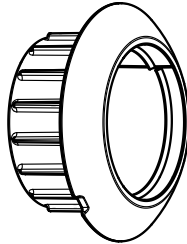

CONICAL NUT

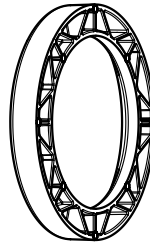

CONICAL WASHER

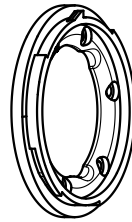

CLAMP RING

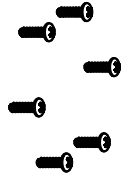

6X SCREWS

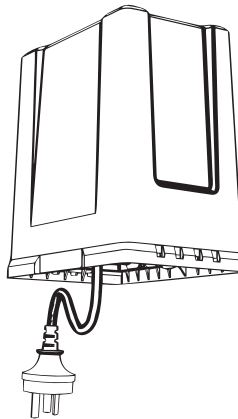

LV25-12 / LV50-12 DUAL
TRANSFORMERS
(INCLUDED IN SINGLE / DUAL LIGHT KITS)

FINISHED INSTALLATION

All light conduits must be run in individual lengths back to transformer location. An air-loop or junction box must be installed as part of each conduit run to prevent pool siphoning.

NOTE: Conduit should contain a draw-wire to allow easy installation of power cable.

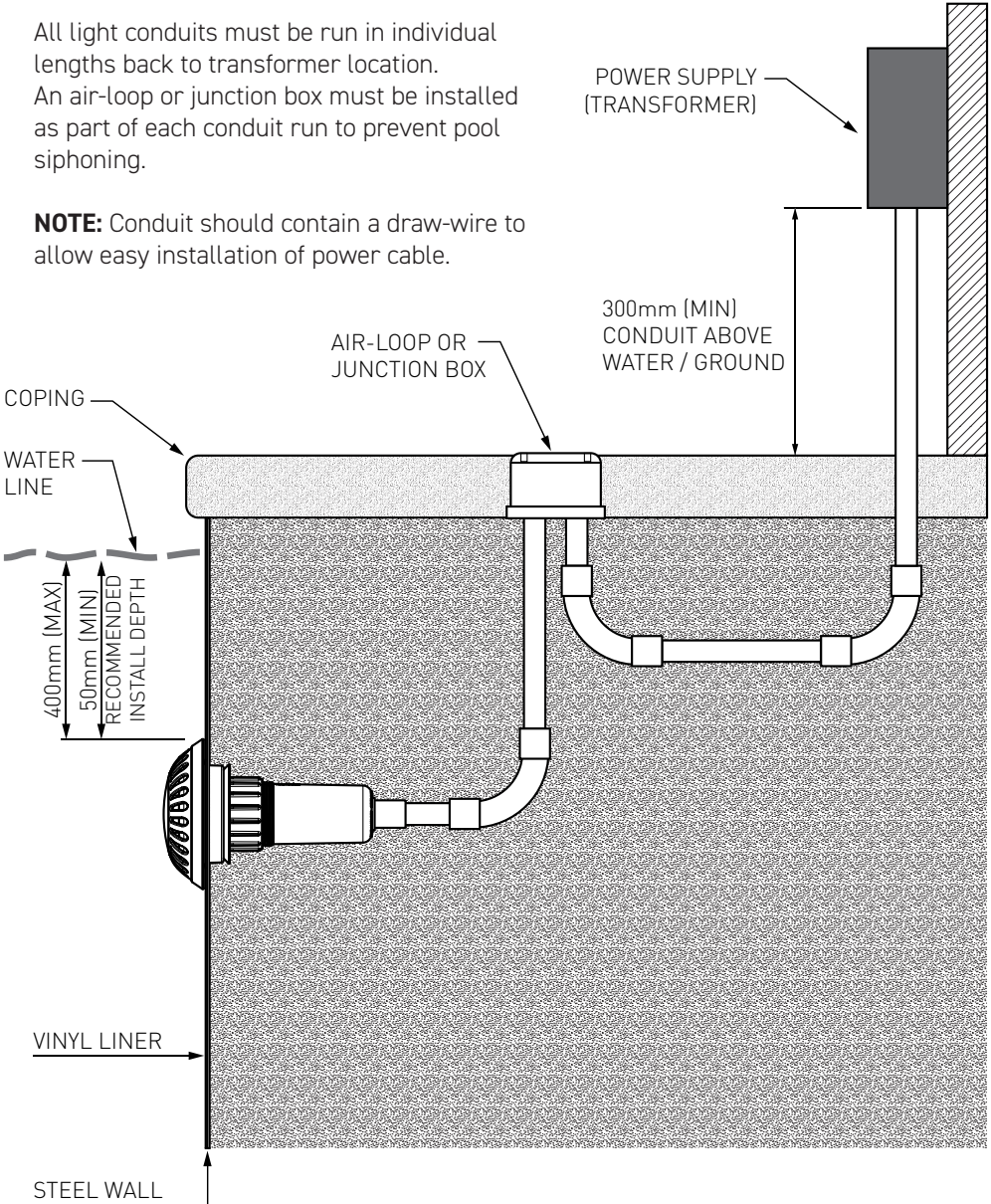

INSTALLATION PROCEDURE

1 MOUNTING HOLE PREPARATION *

* MAY NOT BE REQUIRED IF PRE-PUNCHED / DRILLED HOLES AVAILABLE FOR LIGHT MOUNTING

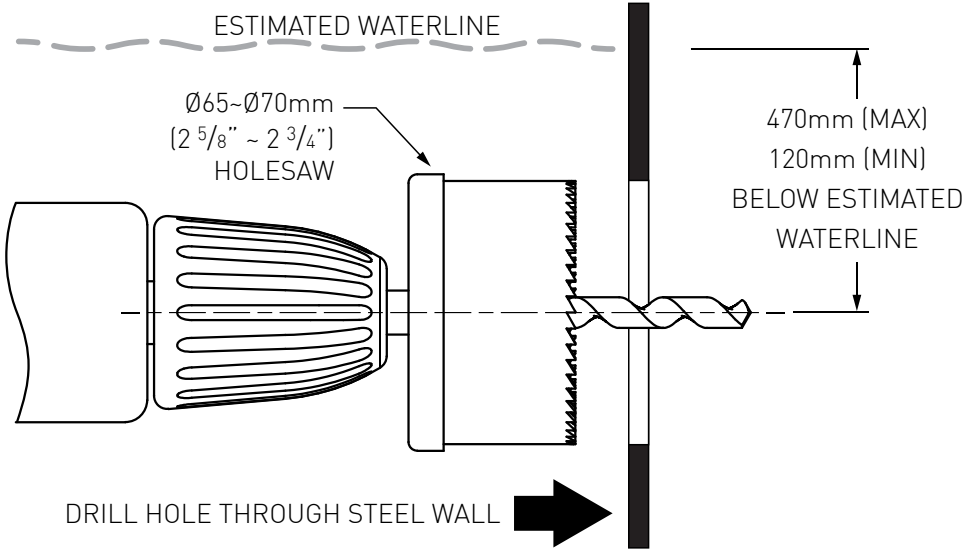

2 ORIENTATION OF NICHE "TOP"

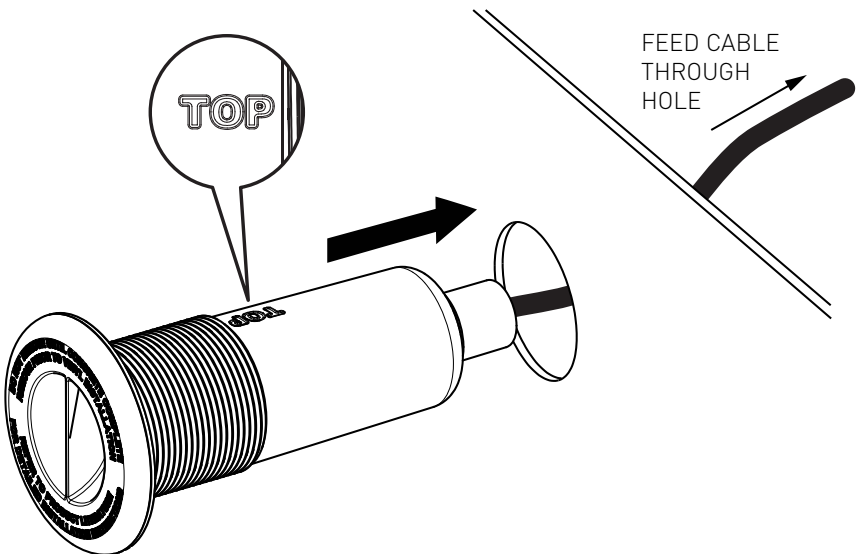

3

ASSEMBLE WASHER AND NUT

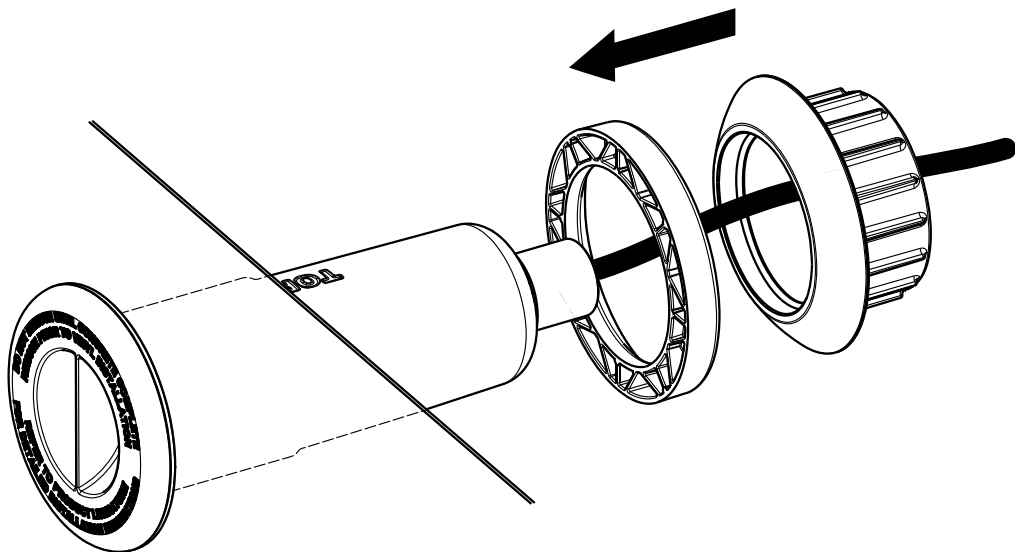

4

TIGHTEN NUT

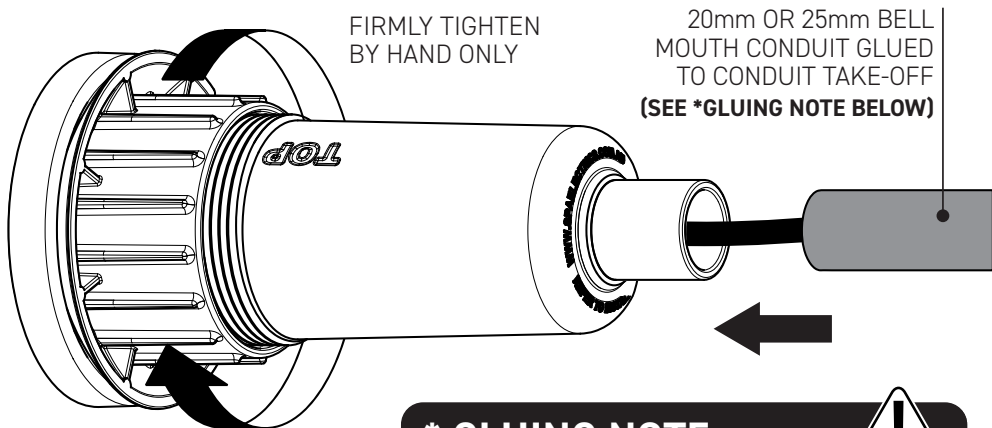

* GLUING NOTE



ENSURE P.V.C. SOLVENT CEMENT IS SUITABLE FOR NON-PRESSURE APPLICATIONS AND USE WITH A.B.S. PLASTIC

5

REMOVE NICHE CAP

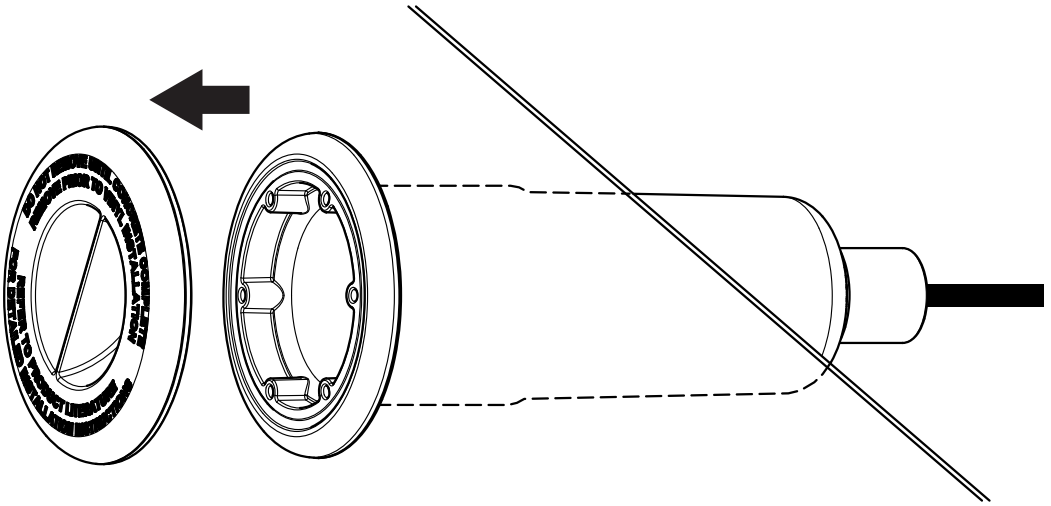

6

ASSEMBLE VINYL CLAMP RING

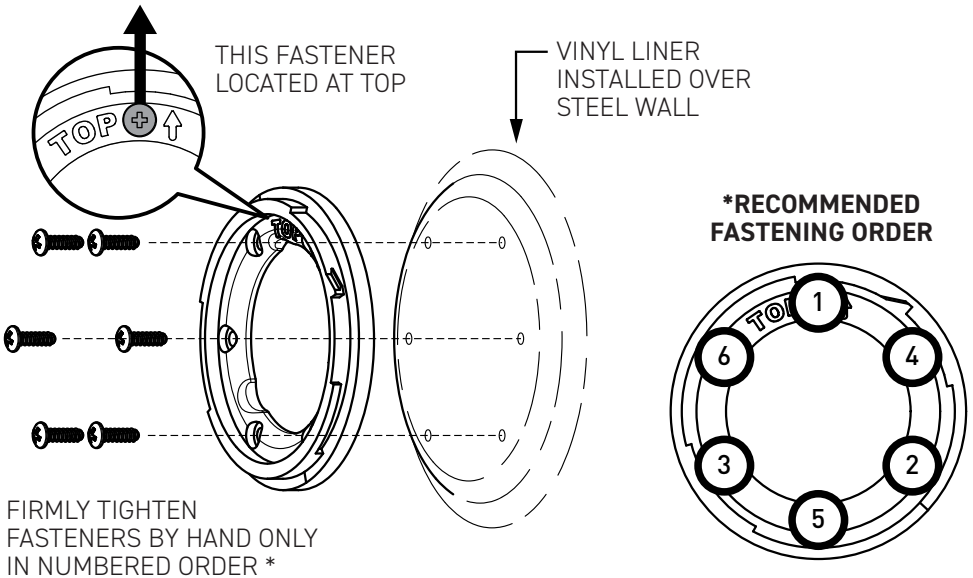

7

TRIM VINYL

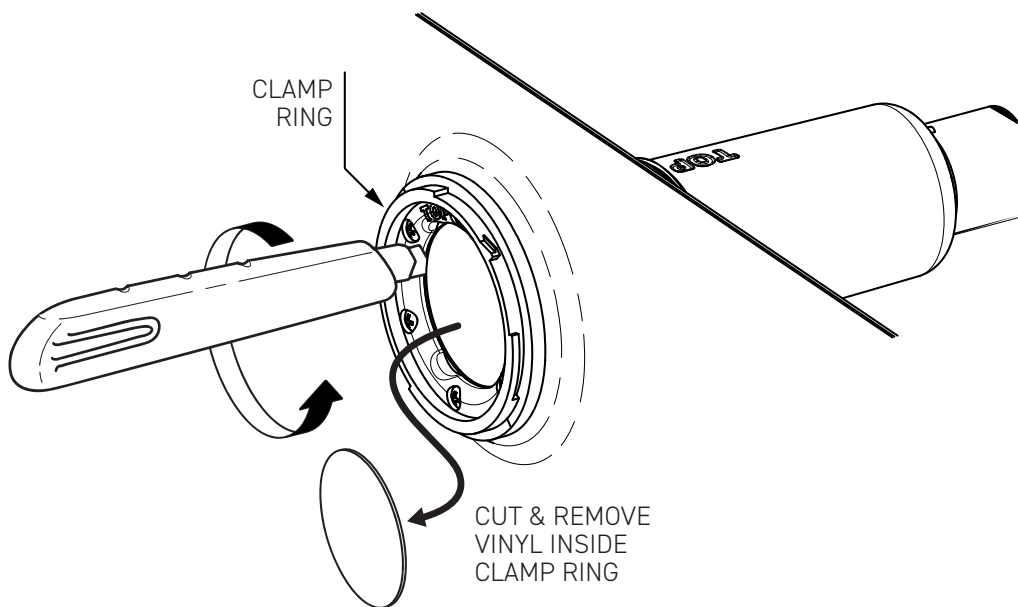

8

REMOVE PROTECTIVE CAP

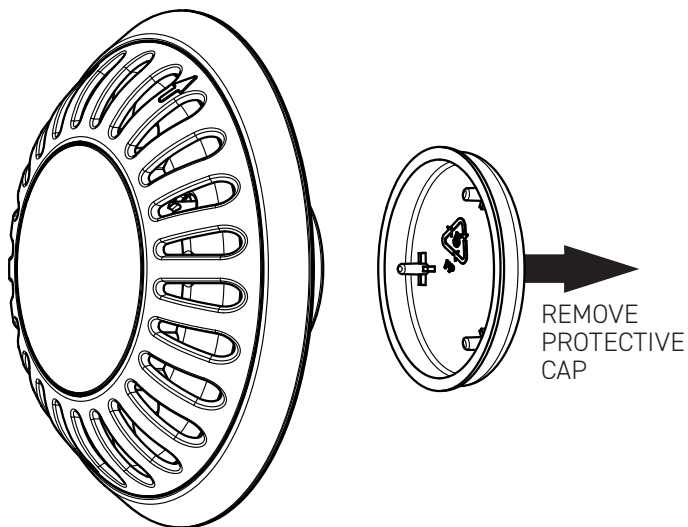

9

REMOVE TERMINAL COVER

NOTE



ENSURE SEAL IS SEATED
FLAT IN PLUG BASE

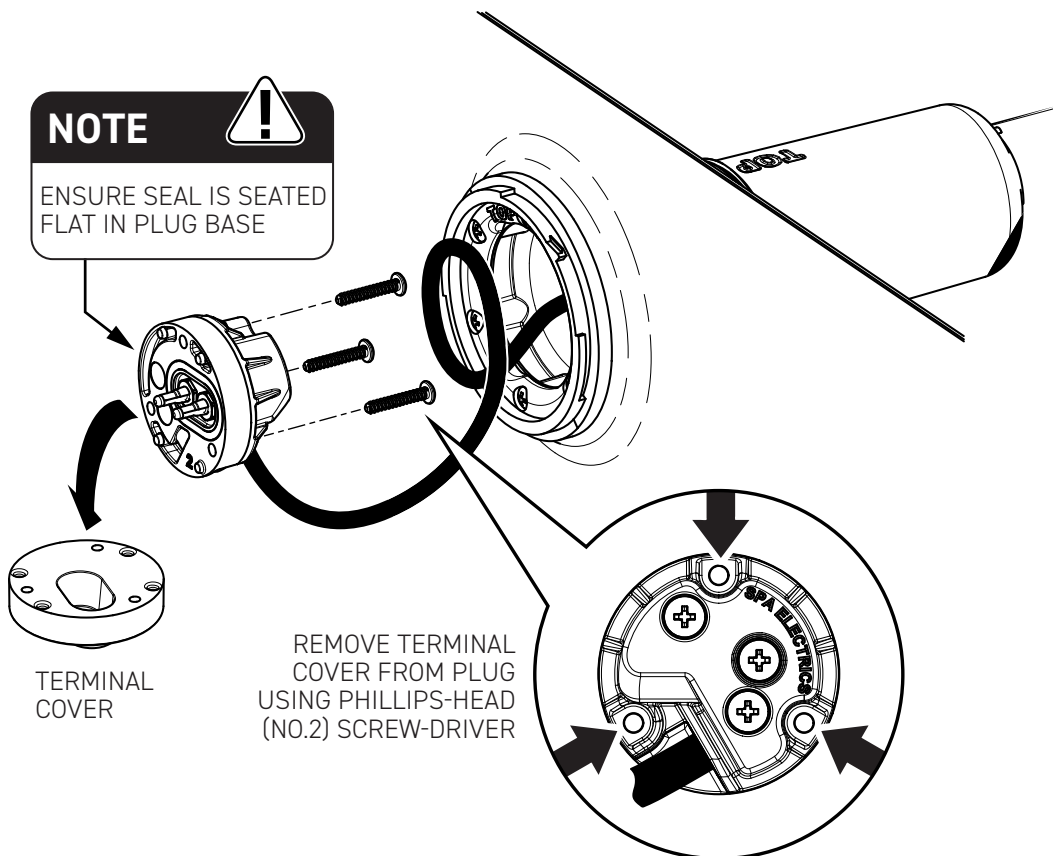

TERMINAL
COVER

REMOVE TERMINAL
COVER FROM PLUG
USING PHILLIPS-HEAD
(NO.2) SCREW-DRIVER

NOTE



DO NOT REMOVE TERMINAL
COVER UNDERWATER

SERVICING



RETAIN TERMINAL COVER IN CASE LIGHT
NEEDS REMOVAL. SEE **PAGE 15** FOR MORE
INFO

10

FASTEN PLUG TO LIGHT

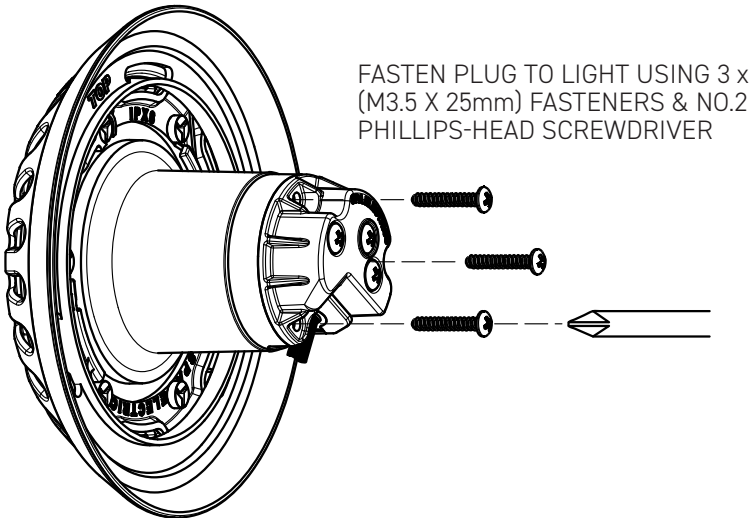
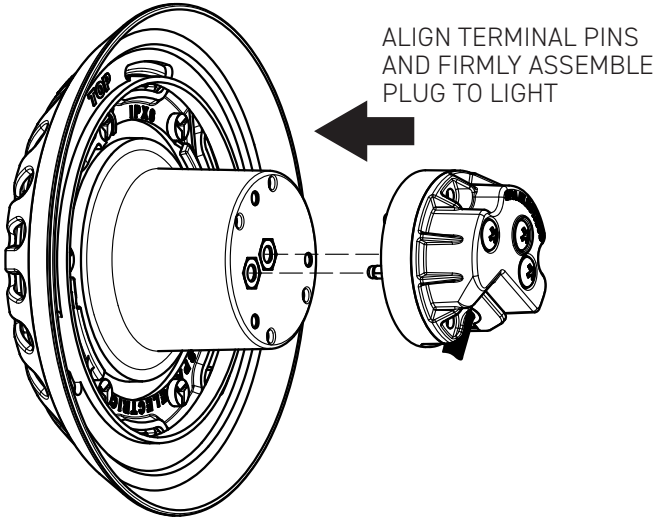

IMPORTANT NOTES



- DO NOT OVERTIGHTEN SCREWS
- DO NOT USE POWER-TOOLS
- DO NOT ADD SEALANTS, GREASES OR ADHESIVES
- ENSURE ALL SURFACES ARE CLEAN AND DRY
- **DO NOT ASSEMBLE UNDERWATER**

LIGHT ASSEMBLY

1 COIL INSIDE NICHE

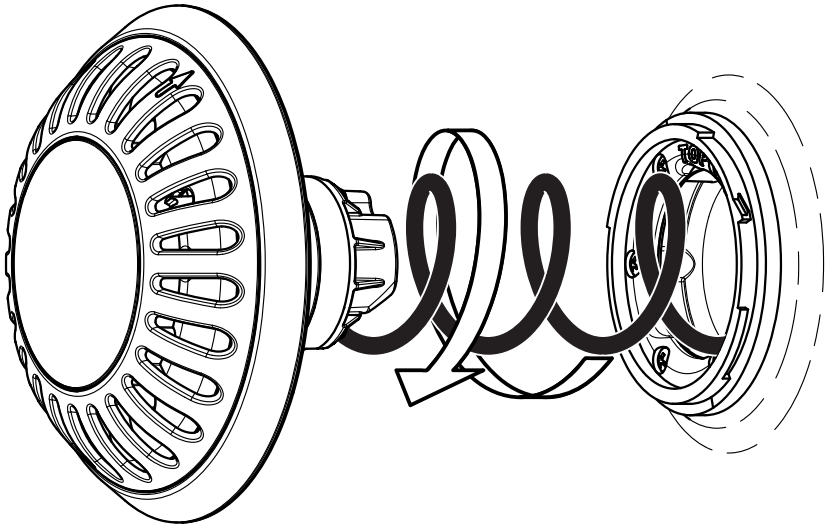

2 INSERT LIGHT INTO CLAMP RING

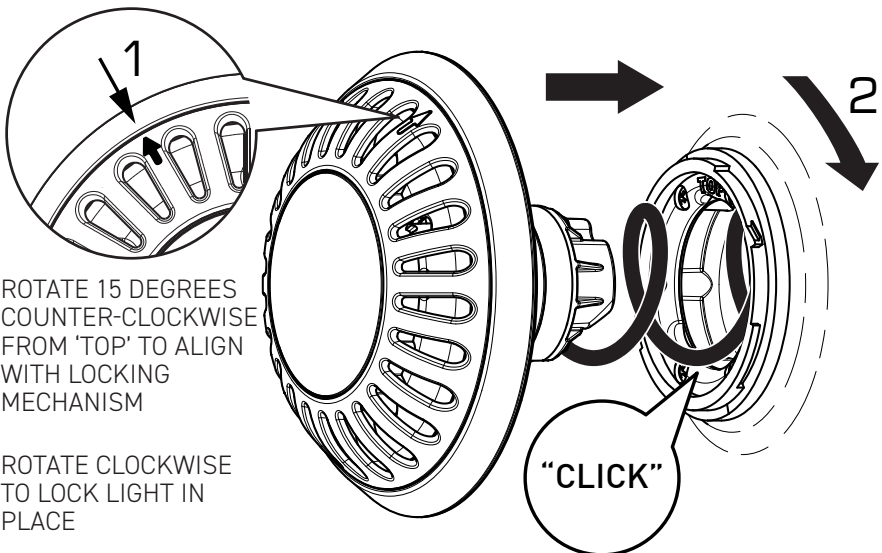

1 ROTATE 15 DEGREES
COUNTER-CLOCKWISE
FROM 'TOP' TO ALIGN
WITH LOCKING
MECHANISM

2 ROTATE CLOCKWISE
TO LOCK LIGHT IN
PLACE

LIGHT REMOVAL

1 PUSH & HOLD BUTTON WITH FLAT BLADE

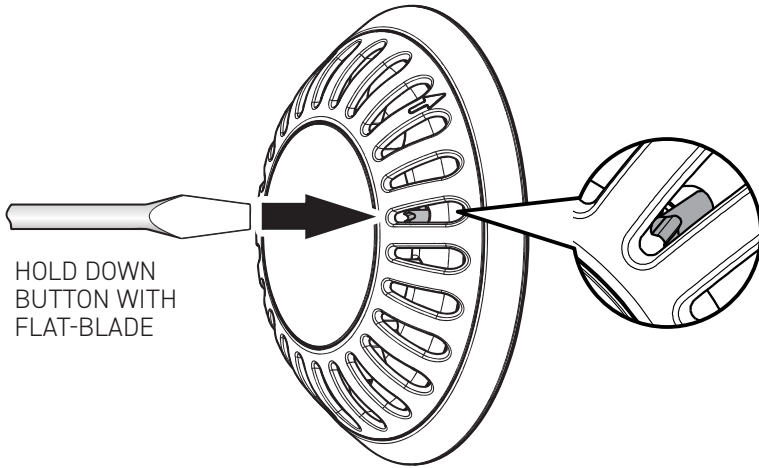

2 ROTATE COUNTER-CLOCKWISE & REMOVE FROM LOCKING RING

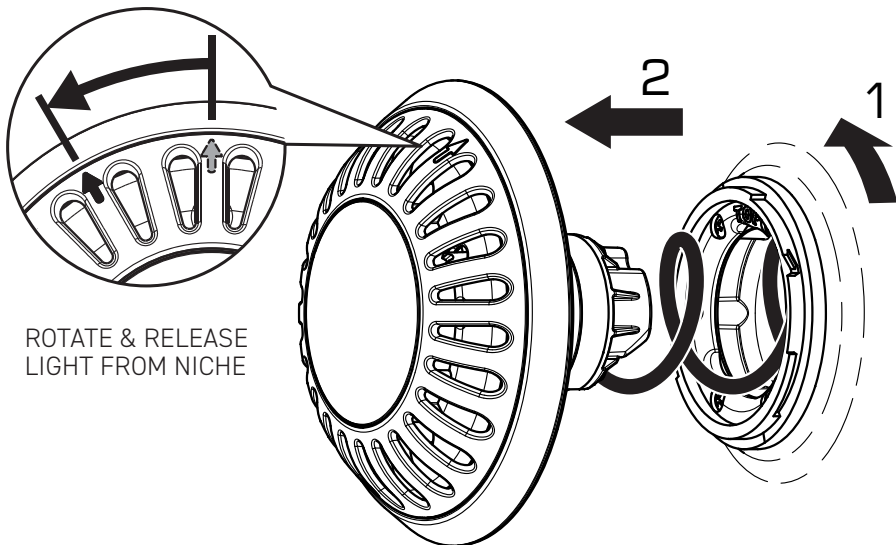

PLUG REMOVAL

1 REMOVE PLUG FROM LIGHT

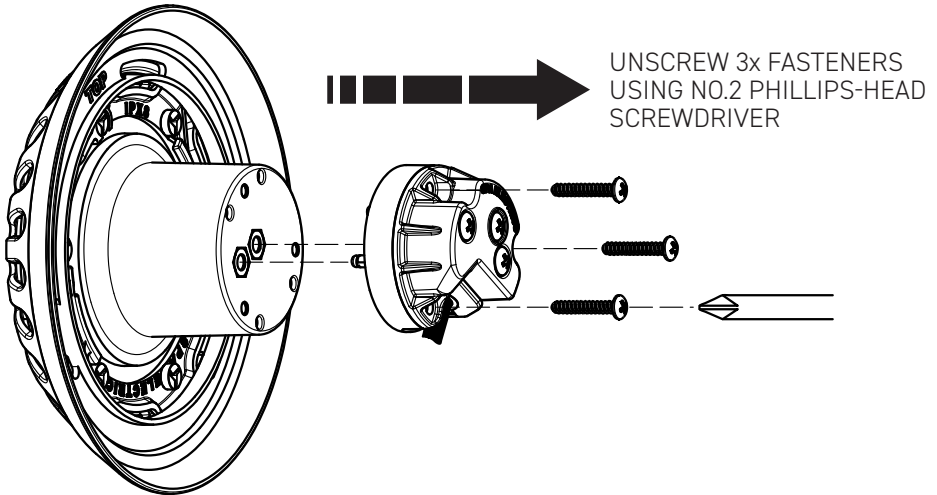

2 ASSEMBLE TERMINAL COVER TO PLUG & STORE IN NICHE

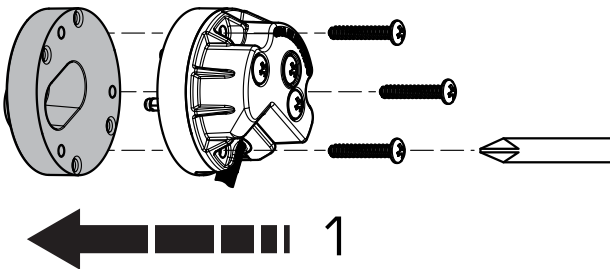

1 ASSEMBLE TERMINAL COVER TO
PLUG USING NO.2 PHILLIPS-HEAD
SCREWDRIVER

2 PLUG CAN BE STORED WITHIN NICHE AS
PICTURED

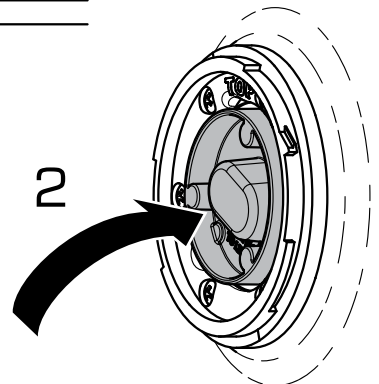

CABLE ADJUST / REMOVAL

ATOM lights (for vinyl pools) are supplied with 700mm of cable pre-installed within the niche. In circumstances where additional cable-length is required, the cable can be extended to a maximum of 1000mm and stored within the niche. (Applicable for cables up to 1.0mm²)

The following diagrams illustrate how the cable can be adjusted and/or removed.

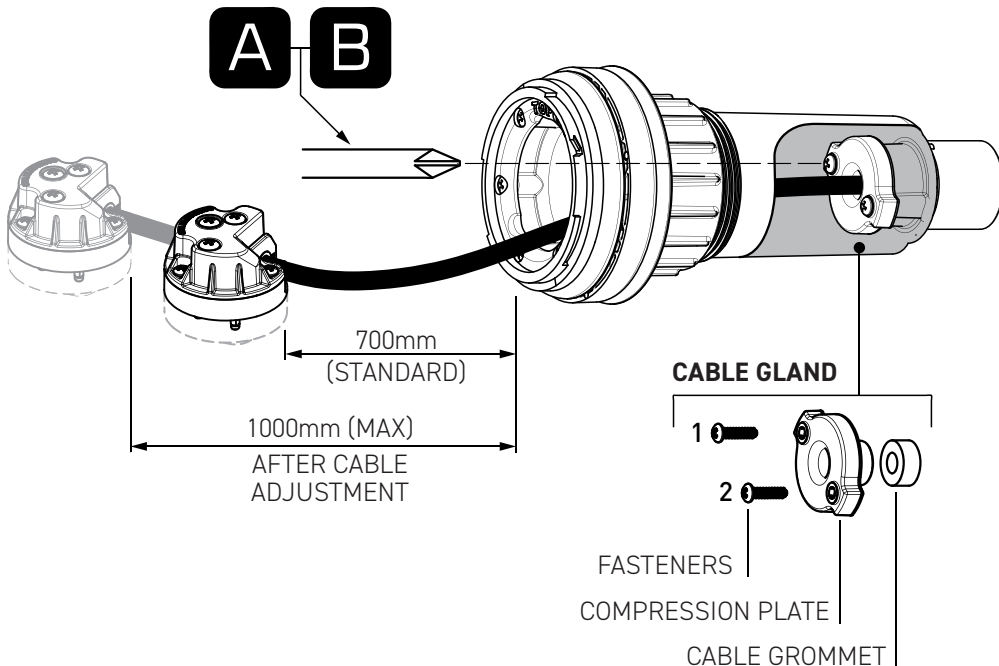

A

CABLE ADJUSTMENT

USING A NO.2 PHILLIPS-HEAD SCREWDRIVER, PARTIALLY LOOSEN FASTENERS 1 & 2 TO ALLOW CABLE TO SLIP THROUGH NICHE.

DO NOT EXTEND CABLE LONGER THAN 1000mm (SEE ABOVE) - EXCESS CABLE WITHIN NICHE WILL RESTRICT CORRECT ASSEMBLY OF LIGHT HEAD.

B

CABLE REMOVAL

USING NO.2 PHILLIPS-HEAD SCREWDRIVER, COMPLETELY REMOVE **CABLE GLAND** COMPONENTS AND STORE SAFELY FOR LATER USE.

ENSURE **CABLE GLAND** COMPONENTS ARE RE-ASSEMBLED TO CABLE IN THE ORIENTATION & ORDER SHOWN ABOVE PRIOR TO FASTENING BACK INTO NICHE.

CABLE ADJUST / REMOVAL CONTINUED...

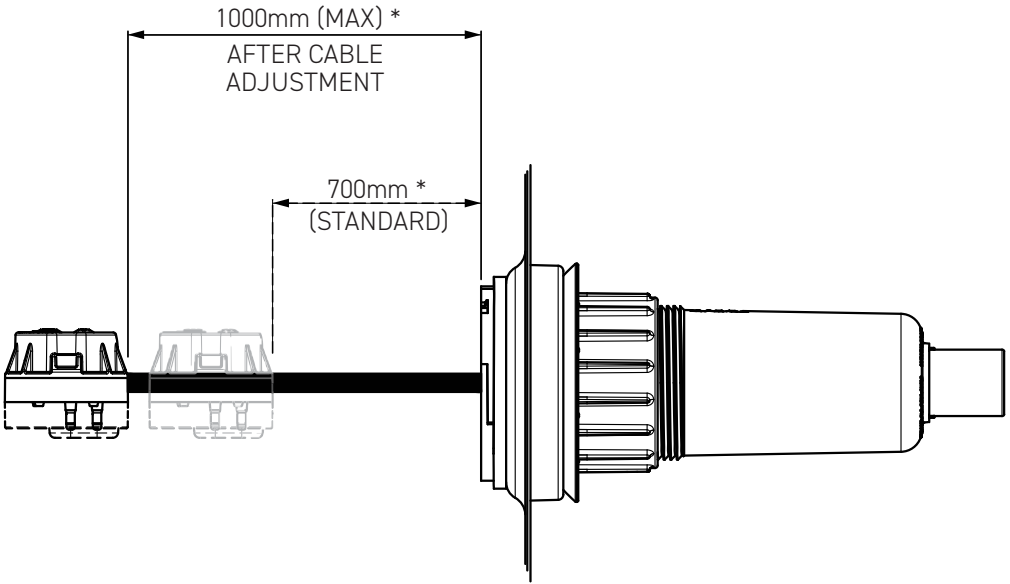

* CABLE LENGTH

CABLE LENGTH MEASURED FROM FRONT OF CLAMP RING TO PLUG'S CABLE-ENTRY POINT

NOTE

ALWAYS ENSURE POOL LIGHT CAN BE RAISED ABOVE WATERLINE FOR INSPECTION & SERVICING

IMPORTANT NOTES

- DO NOT OVERTIGHTEN SCREWS WHEN RE-ASSEMBLING CABLE GLAND COMPONENTS INTO NICHE.
- DO NOT USE POWER-TOOLS
- DO NOT ADD SEALANTS, GREASES OR ADHESIVES TO CABLE OR CABLE GLAND COMPONENTS AT ANY TIME.
- ENSURE ALL SURFACES ARE CLEAN AND DRY PRIOR TO CABLE & CABLE GLAND INSTALLATION
- **DO NOT ASSEMBLE / DISASSEMBLE UNDERWATER**

KEY DIMENSIONS

A NICHE

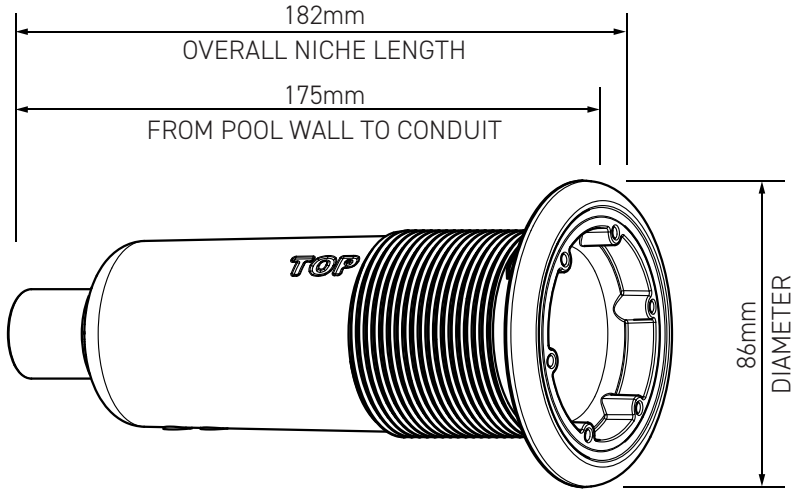

B INSTALLED LIGHT

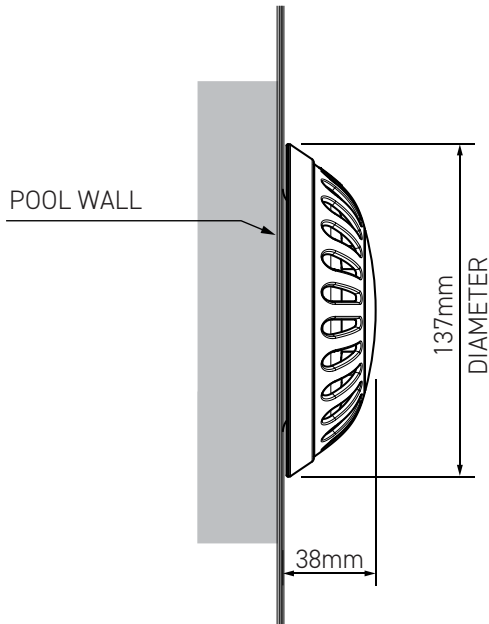



© COPYRIGHT 2024 SPA ELECTRICS PTY. LTD.
ALL RIGHT RESERVED

2024 01 24